

Wiring Diagram – EZGO TXT48 Conversion Kit

Using TAC2 Module PN: 40-000622

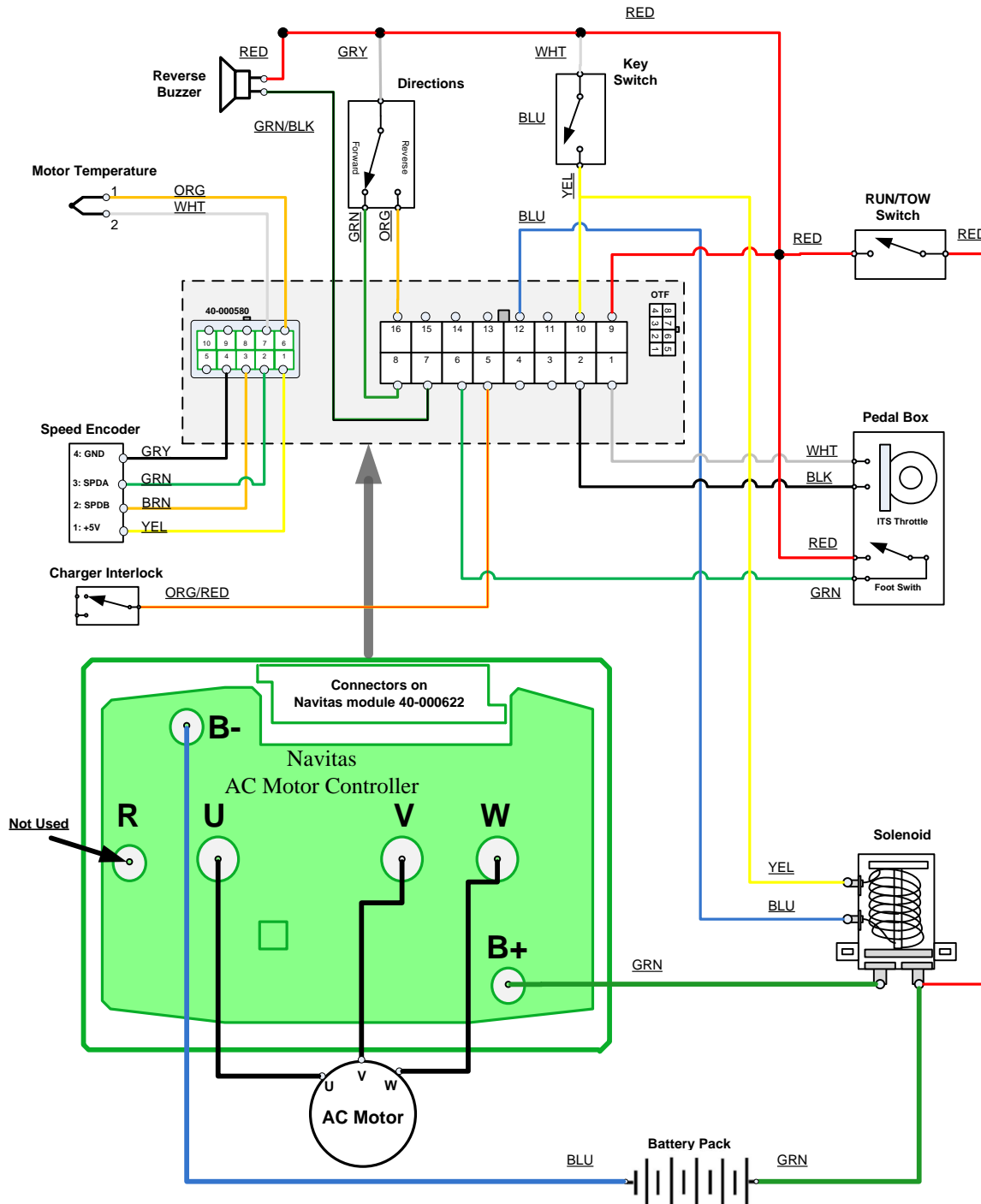

Vehicle Harness
16-POS Molex
39-28-1163

AC Motor Adapter

On The Fly Programmer

- P1: ITS THROTTLE-
- P2: ITS THROTTLE+
- P3: Fused GND
- P4: NA
- P5: Charger Interlock Input
- P6: Foot Switch In
- P7: Reverse Buzzer
- P8: Forward In
- P9: Logic Power In
- P10: Key In
- P11: NA
- P12: Main Solenoid Out
- P13: NA
- P14: NA
- P15: NA
- P16: Reverse In

- P1: WHT
- P2: PUR/WHT
- P3: YEL
- P4: NA
- P5: LT.BLU
- P6: GRN
- P7: ORG/WHT
- P8: BRN
- P9: GRY
- P10: TAN
- P11: NA
- P12: BLU/WHT
- P13: NA
- P14: NA
- P15: NA
- P16: BLU

8 POS Molex
39-01-3089 Housing
39-00-0040 Pin



- P1: +12V POLY
- P2: OTF REGEN
- P3: OTF SPEED
- P4: OTF ACCELERATION
- P5: +5V EXT
- P6: OTF LOOCK
- P7: REVERSE BUZZER
- P8: GND POLY

AC Motor Adapter

10 POS Molex
39-01-3109 Housing
39-00-0040 Pin

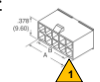

- P1: +5V PF
- P2: Encoder A In
- P3: Encoder B In
- P4: Digital GND
- P5: Encoder C In
- P6: Motor Temperature In
- P7: Analog GND
- P8: NA
- P9: Key In
- P10: Motor Brake Solenoid Release
- P1: YEL
- P2: GRN
- P3: BRN
- P4: GRY
- P5: NA
- P6: ORG
- P7: WHT
- P8: NA
- P9: NA
- P10: NA

Revision History

20210415 Original